

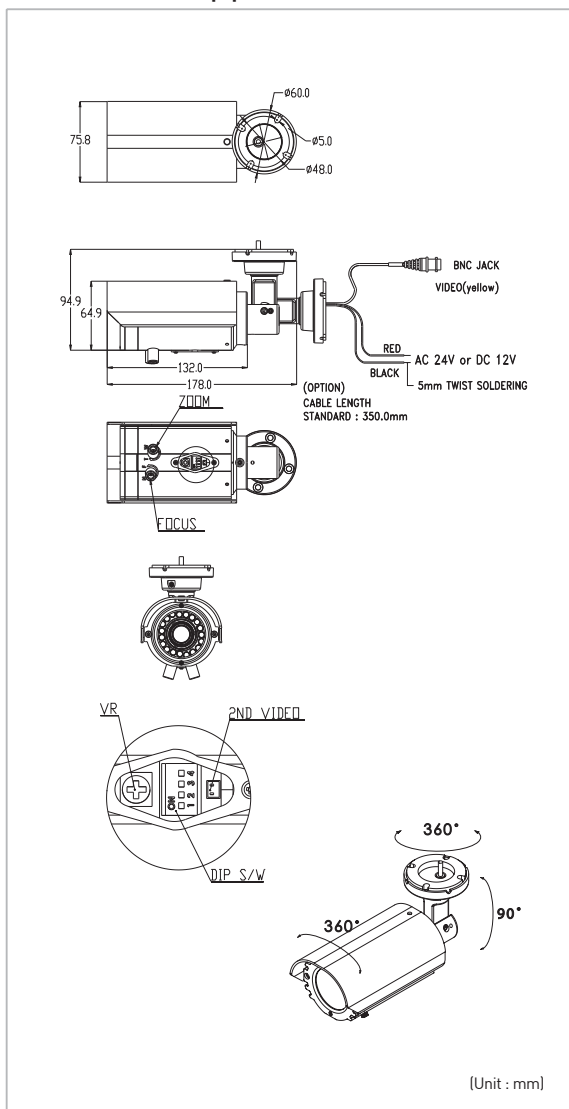

■ Outward Appearance



■ Features

- IR Lamp Synchronizing (CDS sensor)
- High resolution picture quality through digital signal processor
- Wide voltage input operation
- Easy installation & operation
- Protection against rain and wind (IP66)
- Heater function
- Second video output
- IR-Corrected DC Iris Lens

■ Lens Options

- VARIFOCAL LENS: 3.3-12MM

■ Specifications

General Spec	KB-V60IR	
	NTSC	PAL
Sensor	1/3" Interlaced color CCD	
H,Resolution	550	
Scanning system	525 Lines interlaced	625 Lines interlaced
Video output	Composite (1.0Vp-p), 75Ω	
Synchronization	Internal / Line Lock	
Electronics iris	1/60 ~ 1/100,000	1/50 ~ 1/100,000
Light sensitivity	COLOR→B/W: 4Lux, B/W→COLOR: 10Lux	
Gamma	0.45	
S/N Ratio	48dB	
Input voltage	DC10-20[V], AC20-28[V]	
Power consumption	MAX 8.4[W]	
Operating temperature	-10°C ~ +55°C	
Storage temperature	-20°C ~ +70°C	
Operating Humidity	90% RH (non-condensing)	
Connection	Video	BNC Cable
	Power	2P WIRE
Dimension	178.0(Ø) X 75.8mm	
Weight	245g	
Certification	CE/FCC	